



November 2021 | Edition No.2

AMICREST

Amity International School, Saket



Dr (Mrs) Amita Chauhan

Chairperson, Amity Group Of Schools



The aim of education is the knowledge not of facts, but of values. Happiness is the state of consciousness which proceeds from the achievement of one's values. Follow the compass of values and align yourselves to harmony, cooperation, sharing and reverence for life.

As educated as one may be, a sense of morality is what guides us to use our knowledge in the right direction and to put it to good use. This ultimately benefits mankind. It is a strong value system and a good moral compass that make the voice of reason speak out when one is faced with a choice between the right and the easy way around a problem. A person with good values will always be respectful, helpful, honest, fair, non-judgemental, kind-hearted and accommodating and all these qualities will earn him or her a special place in everyone's hearts.

Peace of mind generates right values, right values promote right action and right action induces excellence. Open your arms to the winds of change but don't let go off your values.

EVENTS



AZADI MAHOTSAVA

Drawing Inspiration From Heroes Of The Past!

'Freedom is not given, it is taken!'

- Subhash Chandra Bose

A special programme in the honour of Netaji Subhash Chandra Bose was organised and showcased by the students of Pre-Primary and Primary classes on the online MS-Teams platform on Thursday, 21st and 22nd October '21.

The students of all classes were apprised about Netaji's life and his valuable contribution in nation building through videos and group discussions. The song, 'Kadam Kadam Badhaye Jaa', was played as a tribute and the session concluded with the children echoing the slogan 'Jai Hind Jai Bharat.'

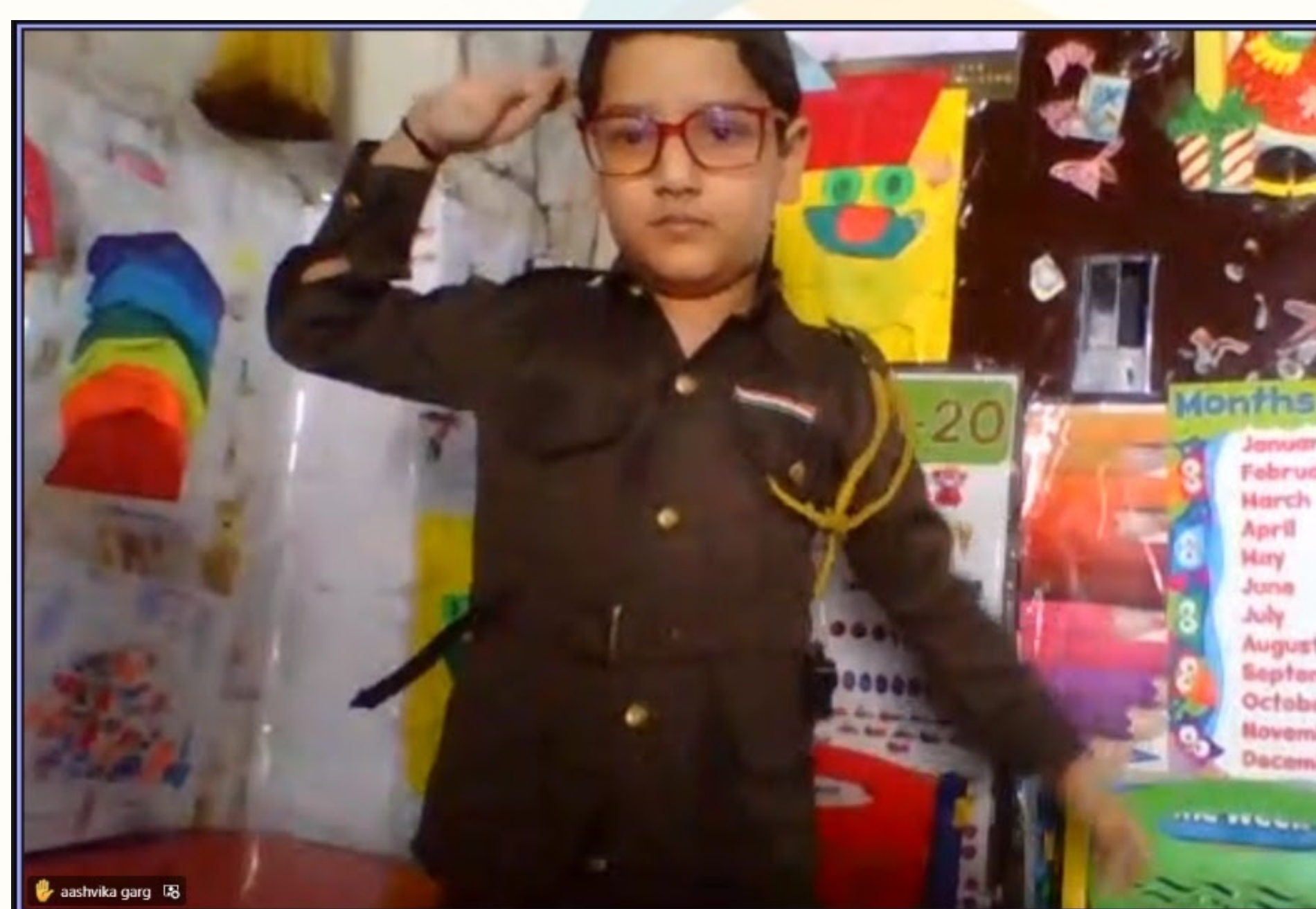
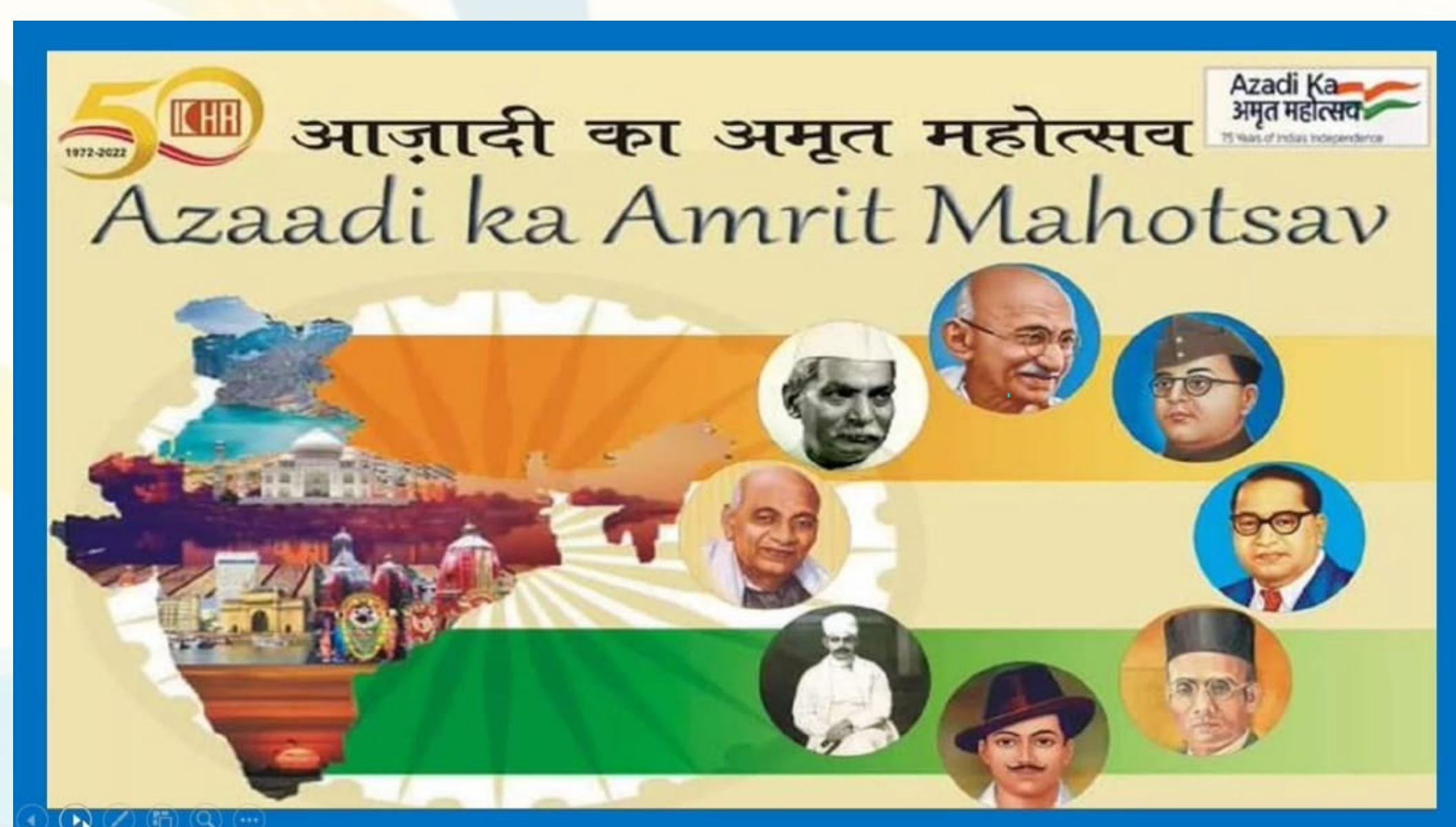

RAMLEELA & DUSSEHRA

Re-awakening The Good Within Us

'Those who have knowledge of dharma say that truth is the highest dharma.'

– Ramayana

Our Pre-Primary Amicians from Nursery and KG class, revived the true essence of Ramayana and Dussehra for all of us virtually on Wednesday, 13th October, 2021.

The program showcased melodious bhajans sung and performed brilliantly by our enthusiastic Amicians. Our pre-primary students enthralled everyone with their superb portrayal of various characters from the 'Ramayana' reminding us to always choose wisely between the right and the wrong, thus winning applause and appreciation from everyone.

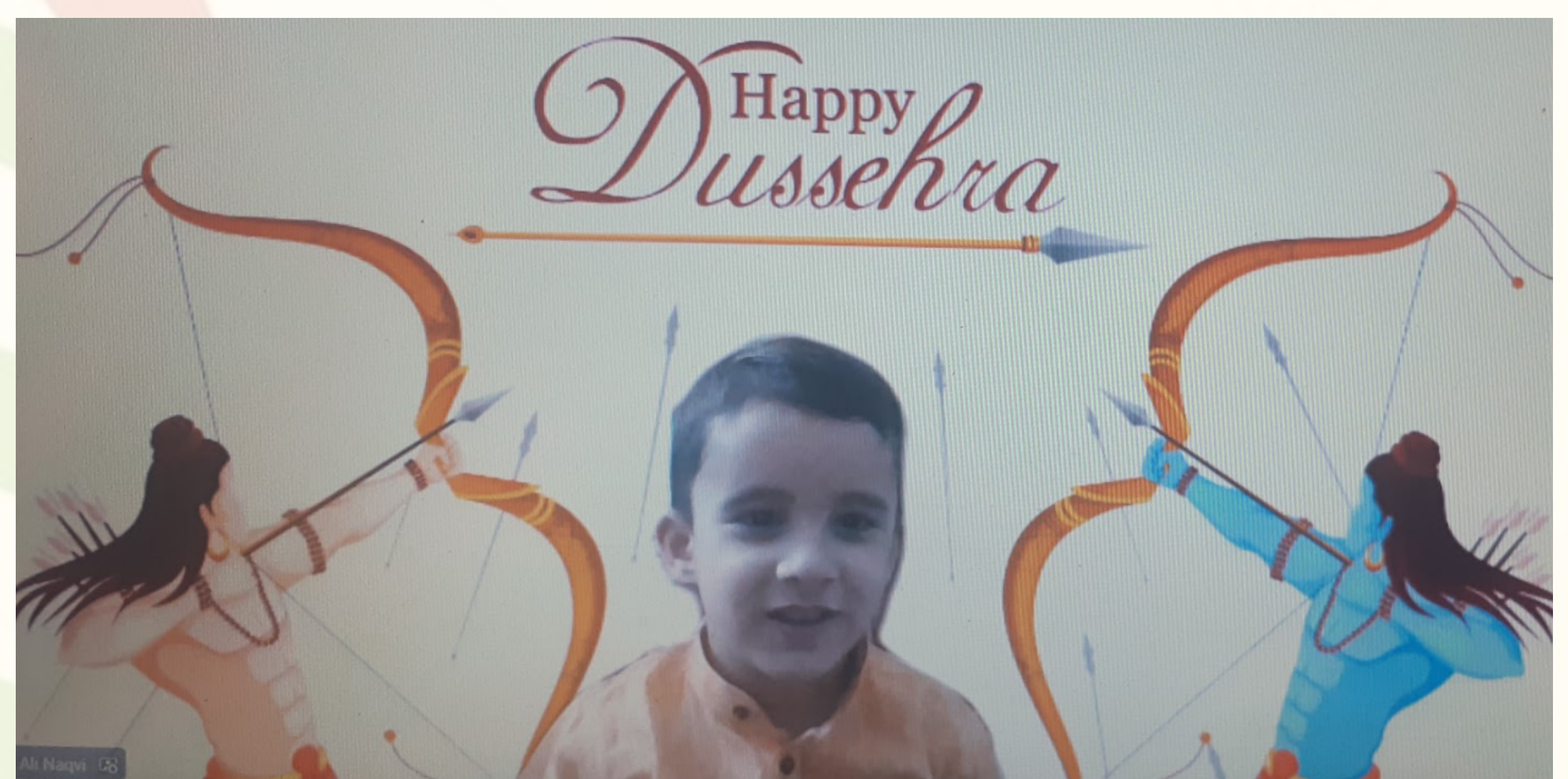
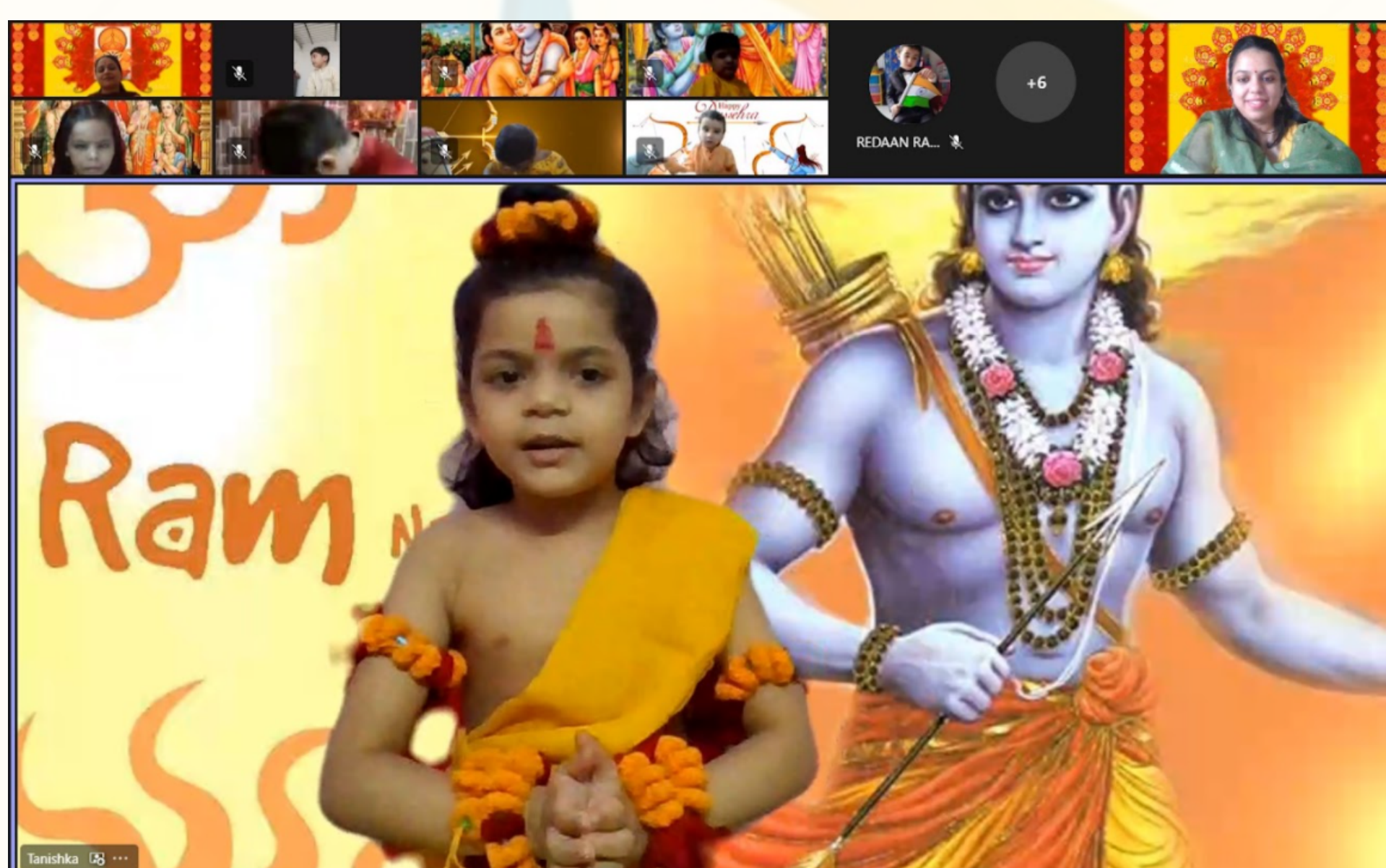
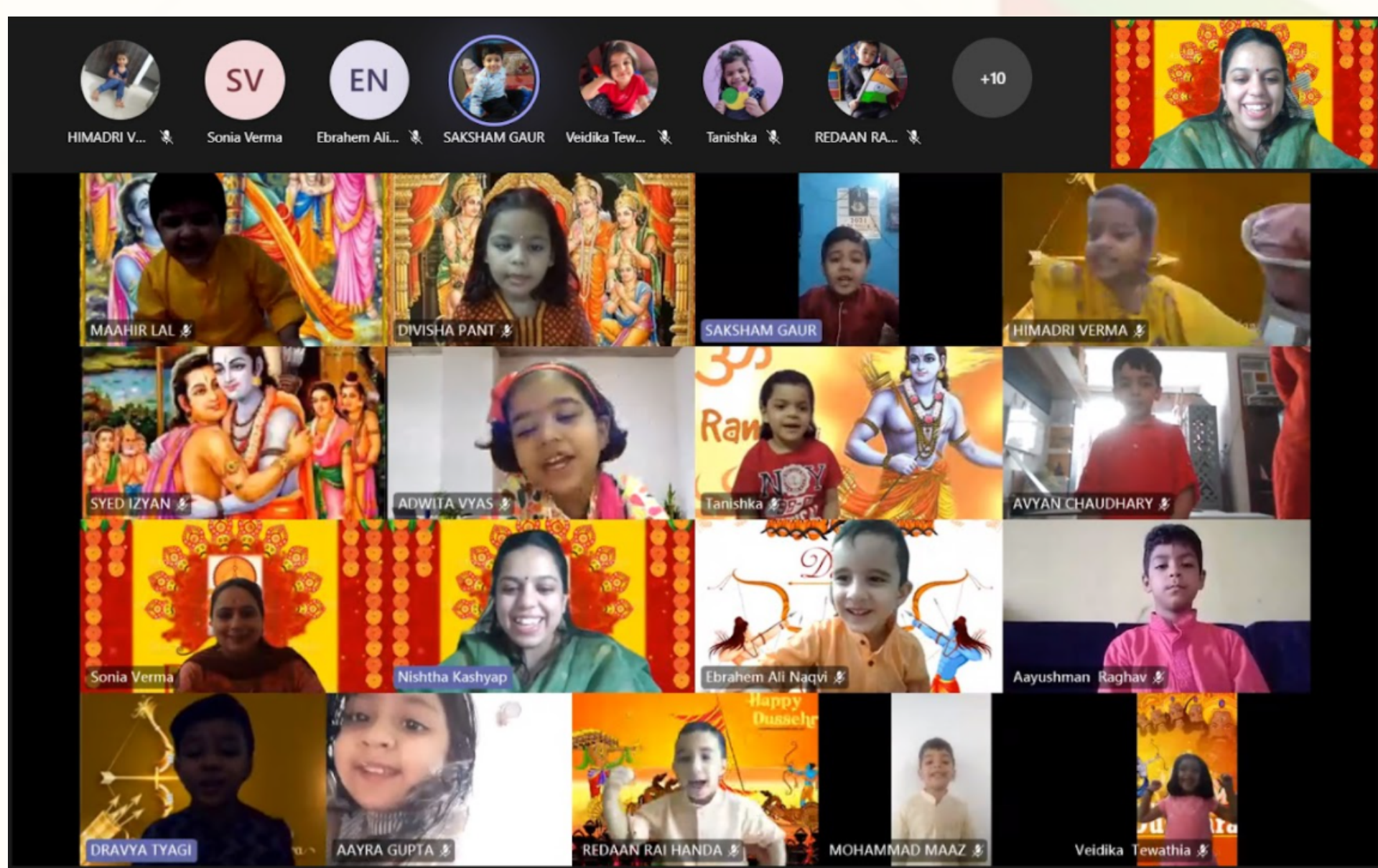

DELHI STATE ROLLER SKATING CHAMPIONSHIP

A Story of Speed On Wheels

From the tender age of four, Viraj started skating and has already bagged 4 trophies, 63 gold medals, 25 silver medals and 8 Bronze medals till now.

23rd October '21 turned out to be a special day, when he won a bronze medal in the Delhi State Roller Skating Championship and this is his 100th medal in Inline Skating. He has been representing Delhi state in a lot of prestigious events organized by CBSE and RSFI inline Skating competitions at state and national levels. Kudos Viraj!!



TENNIS PREMIER LEAGUE

A Grand Swing On The Grass Court

Praneel Sharma, a student of class VIII-A has been selected by Delhi Binny's Brigade as their top Boys U-14 player for the 3rd season of Tennis Premier League (TPL). The Delhi team is headed by International Player Yuki Bhambri. The TPL is the Lawn Tennis Premier League being played among 8 teams of India representing different regions. The league will be played from 9th to 14th December '21 in Mumbai and will be available live on SonyLiv. He was selected through a Talent Hunt competition played in R K Khanna Stadium, DLTA New Delhi where he won 7 rounds (matches) to become eligible for selection. Kudos Praneel!!



ATL TINKERPRENEURS



Tycoons Of Tomorrow

The ATL Tinkerpreneur Bootcamp organized by Atal Innovation Mission, India was a 2 month long summer boot camp which helped equip students to create their own online venture. Around 25 students participated in the bootcamp and project of Aditri Bhatnagar (Class VII) was selected in the top 100 innovators and entrepreneurs, whereas (i) Kritika Singh (Class X) and (ii) Business Enthusiasts (Lakshita Agrawal, Anwasha De, Jhanvi Roy, class IX) were selected as the most consistent students. Kudos Aditri, Kritika, Lakshita, Anwasha and Jhanvi!!

[A]

ATL Tinkerpreneur Top 100 Students					
 					
Congratulations to the student innovators and entrepreneurs! We are proud of you and we hope you continue the excellent work and keep innovating!					
<small>Selection Process: Students who have submitted assignments for atleast 5 out of 9 weeks and have submitted the Week 9 assignment, underwent an evaluation from a Mentor of Change as well as from a Jury of Atal Innovation Mission. The top scoring 100 entries were selected.</small>					
S.No	ATP Code	ATL Code	Name/Team Name	School Name	State / UT
79	13355491	fd862022	Aditri	fd862022Amity International School	DELHI

[B]

ATL Tinkerpreneur Most Consistent Students					
 					
Congratulations to the student innovators and entrepreneurs! We are proud of you and we hope you continue the excellent work and keep innovating!					
<small>Selection Process: Mentors who have evaluated every assignment submitted by their students</small>					
S.No	ATP Code	ATL Code	Name/Team Name	School Name	State / UT
52	18456463	fd862022	Kritika Singh	fd862022Amity International School	DELHI
368	275710372	fd862022	Business Enthusiasts	fd862022Amity International School	DELHI

AK SAHA COMPETITION

A Quest Into The Savants Of Science

‘AK Saha Memorial Young Scientist’ competition is an inter school event conducted by Springdales School, Dhaula Kuan. The event comprised of a science quiz in which Harsaaj Singh Wander and Aditya Aggarwal of class XII participated. The competition also had an interesting investigatory project category witnessing a qualitative participation from Kashvi Goel and Anwasha Satpathy of class XI. The team won the prestigious overall rolling trophy. Kudos Harsaaj, Aditya, Kashvi and Anwasha!!



IGNITED MIND 2021

Soaring Ingenuity With Wings Of Fire

Himanshu Sharma, XI C received the appreciation certificate for the project 'Weed Detection Mechanism' in the APJ Abdul Kalam Ignited Mind Children Creativity and Innovation Award 2021.

Kudos Himanshu!

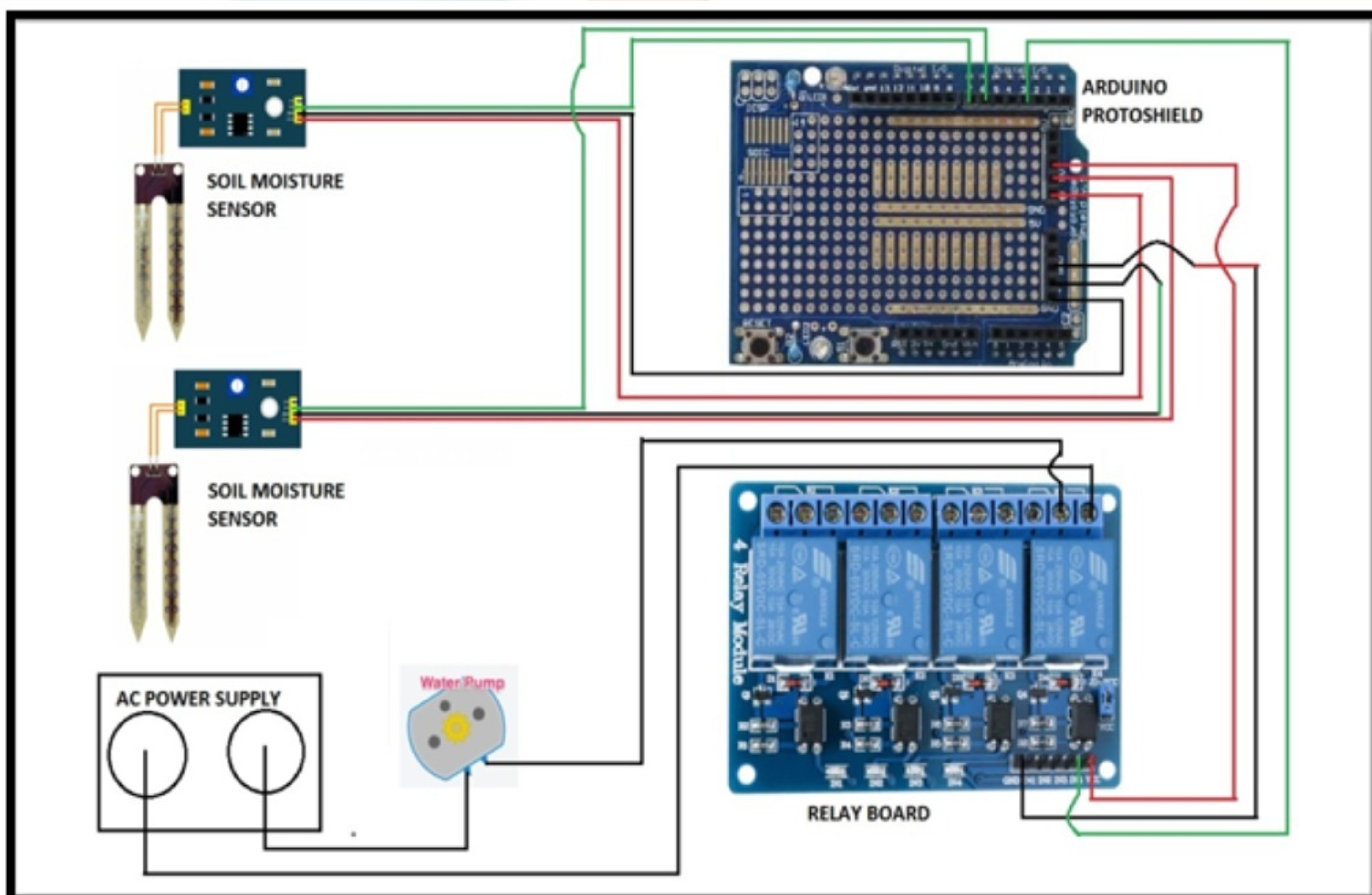

BREAKOUT '21

A Mesmerizing Music Competition

With the blessings of our honourable Founder President Dr Ashok K. Chauhan and esteemed Chairperson Dr. (Mrs.) Amita Chauhan, The Western Music Society of Amity International School, Saket, New Delhi organised the second virtual edition of BreakOut '21 with the aim to give young and talented musicians from various schools an opportunity to perform and showcase their talent.

The entire event was divided into two categories-live and pre recorded. The Solo Singing and the Original Composition were pre recorded. The other category was live Instrumental performance online. This consisted of electric guitar, acoustic guitar, piano, keyboards, bass guitar, drums and unique instruments.

The panel of eminent judges comprised of Mr. Edwin Fernandes, professional musician from Goa; Mr. Mario Sequeira, solo musician and Mr. Cajetan John D'Costa who appreciated the mellifluous performances.

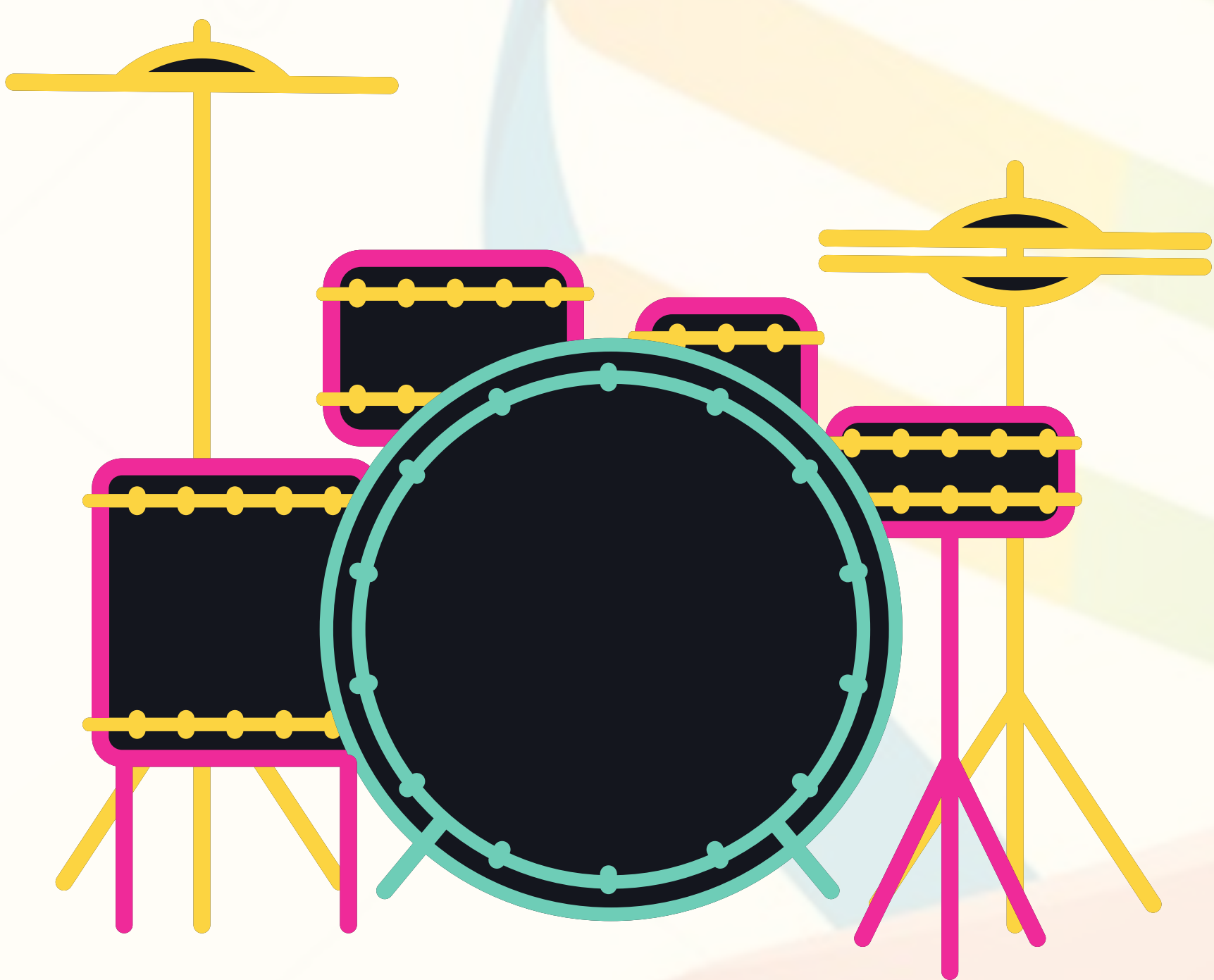
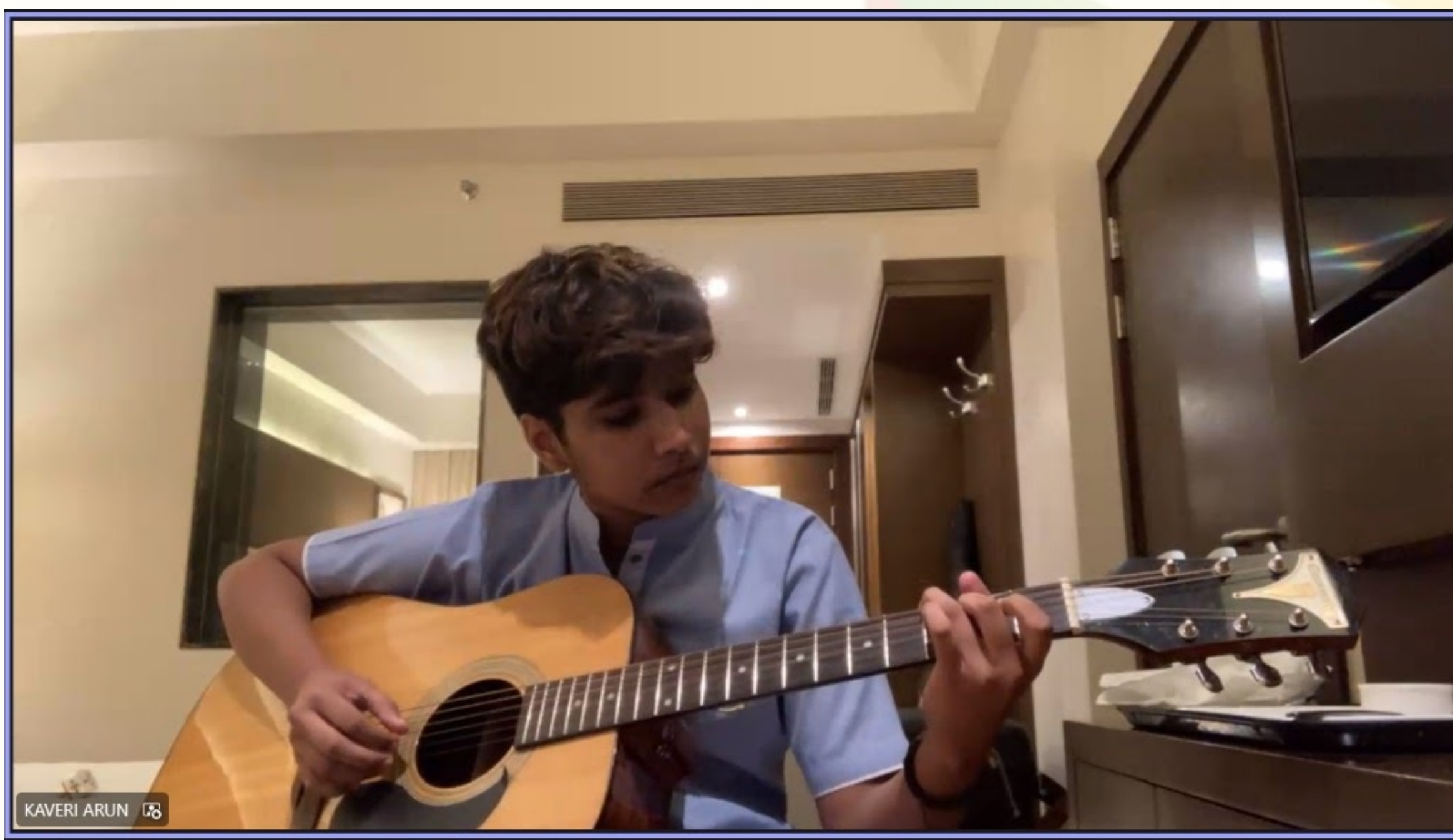



VIGYAN VEER SCREENING

A Blazing Trail Of Glory

Aayushi Kaushik of Class XII G was interviewed by Vigyan Prasar, Department of Science and Technology, Government of India on the 29th of October for her project YUVTI, one of the top 60 awardees of the Inspire Manak Awards. The shoot was a broadcast on their video programme 'Vigyan Veer' and other social platforms. Kudos Aayushi!!



AIMUN '21

Discretion, Discussion and Diplomacy

Amity International School conducted the 17th edition of Amity International Model United Nations (AIMUN) from the 24th-25th of September, 2021. The conference featured the UN General Assembly, UN Security Council, UN Development Programme, World Health Organization, Lok Sabha and the novel Marvel Crisis Committee. Students ranging from classes VIII - X represented their portfolios and debated on issues of international relevance, and endeavoured to carve out resolutions to the disputes.

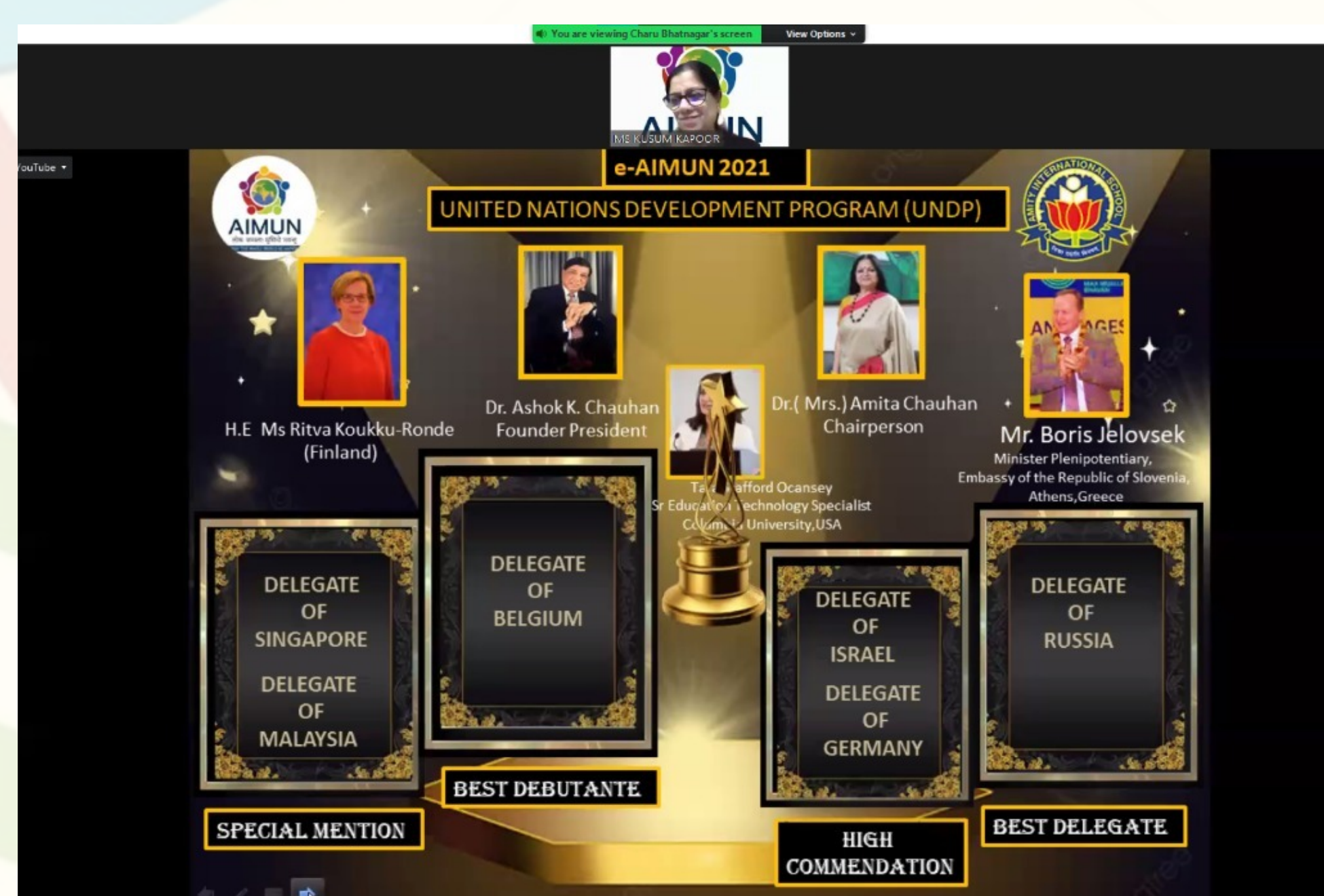
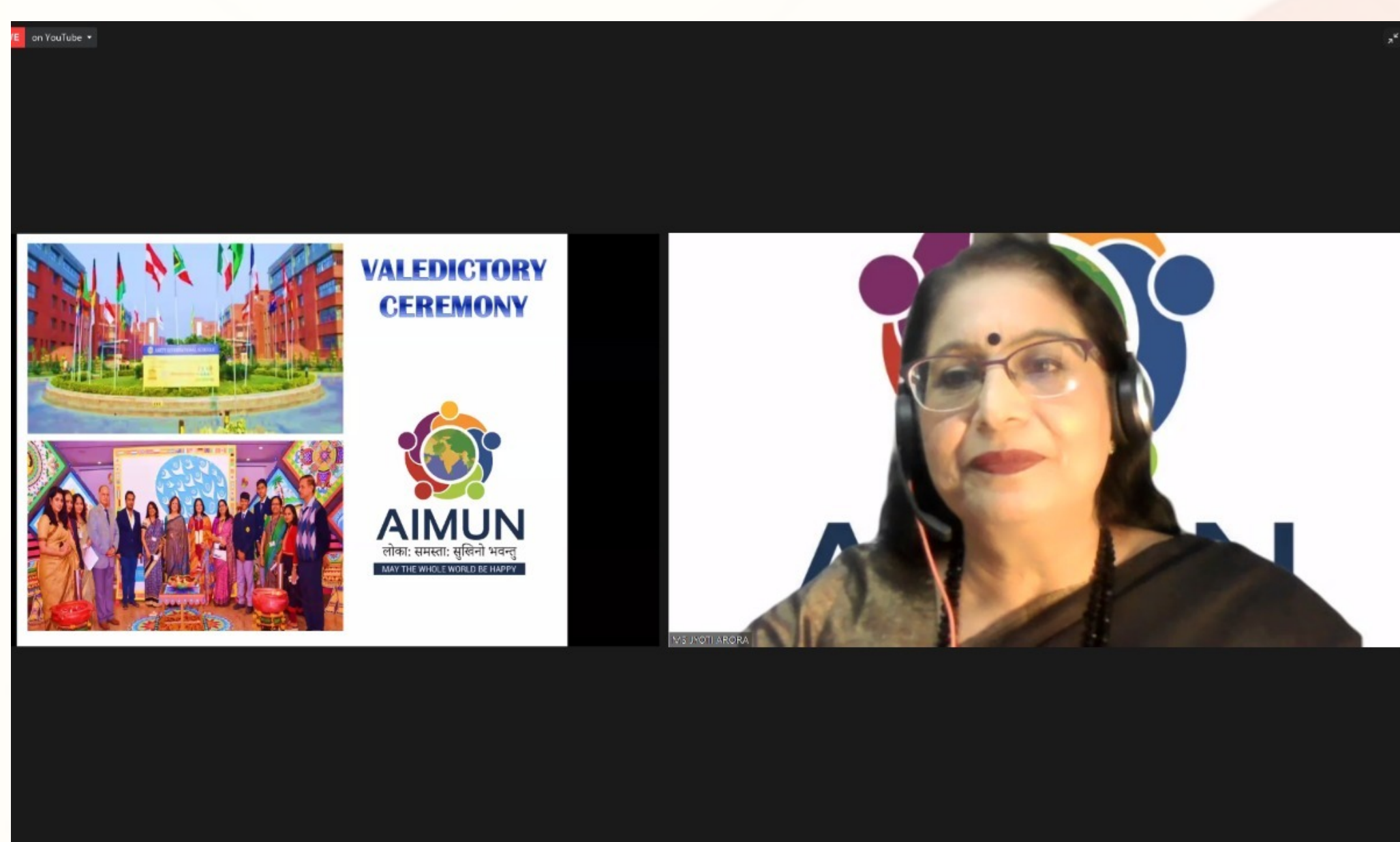

ECOMFORUM '21

Honing Acuity For Financial Finesse

The 22nd Edition and second virtual Ecom Forum, the annual inter school competition of Economics & Commerce was held on October 30, 2021. The event was organised by Rebus along with the commerce department and was attended by XI & XII class students of more than 30 schools. The event comprised of three events namely Economics Symposium, Wisdom Wand and Fintoons. In economics symposium current issues like Intellectual Property Rights, Sri Lanka's Economic Crises, National Monetization Pipeline, UBI viability and Crypto currency were discussed. Wisdom Wand had startups based on social events while in Fin-toons students had to draw financial cartoons on the topics, "Make in India: Upskilling and Reskilling to create Atma Nirbhar Bharat". The Economics Symposium was judged by Prof O.M. Aggarwal and Dr Nisha Gupta. Wisdom Wand- The start up event with a social cause was judged by Ms.Vira Sharma, and Mr. Shankar Bose . Fintoons was judged Ms. Kangan Khanna. The prestigious Late Shri Baljit Ji Shastri Rolling trophy was won by AIS, Noida.



GOCODE 4.0 MEGATHON

Innovations for a better future

Pratul Gupta and Sehen Dey of class 10th came first in the Jack in the App category in the GoCode4.0 Megathon organised by Amity International School, Vasundhara.

Their app Talim converts the usual tedious language learning progress into a simple and playful manner with the help of quizzes and games. It is based on the idea of “Atmanirbhar Bharat” and “Go Vocal for Local”. It includes Indian languages like Hindi, Sanskrit, Bengali, Tamil amongst others.

Advait Pandey of Std VII and Reyansh Vij of Std VIII also participated in wise tech category in the GoCode4.0 Megathon organised by Amity International School, Vasundhara and got selected for the finals. They presented their video on Climate action in the finals.

Kashvi Goel, Yajika Dagar and Anwasha of class XI also participated in Transform IT category in the GoCode4.0 Megathon organised by Amity International School, Vasundhara and got selected for the finals. They presented their innovation, a medicine box that helps the elderly to remember and remind for medicines in the finals.

Kudos Pratul, Sehen, Advait, Reyansh, Kashvi, Yajika and Anwasha!!

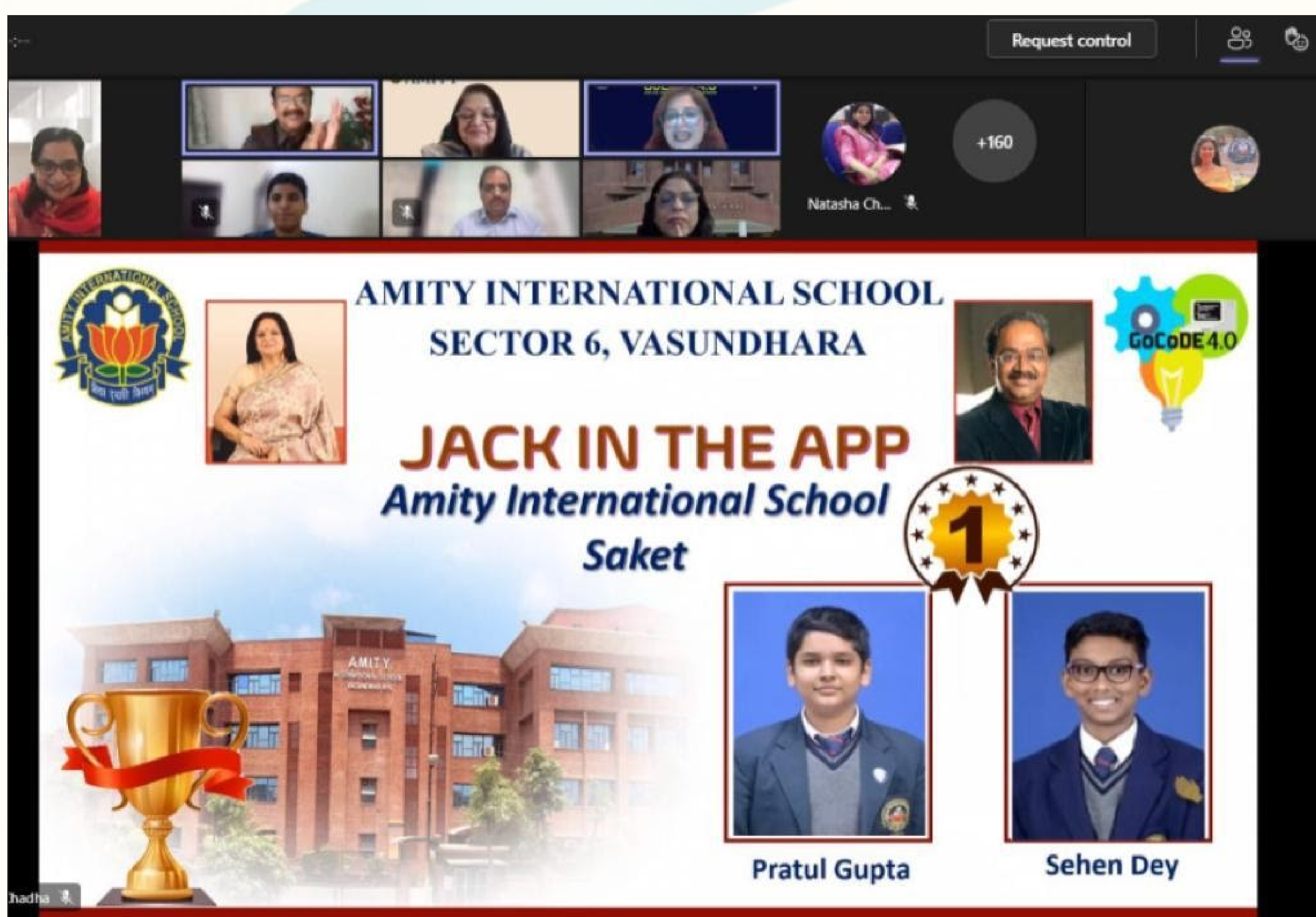

TARANG '21

An Extravaganza In Pursuit Of Happiness

Amity International School, Saket hosted the most awaited event, Amity Tarang for the Leelavati Shastri Award, on Monday, 1st November 2021 in honour of 'Ammaji', the mother of our Chairperson ma'am.

Our venerated Chairperson Dr. Mrs. Amita Chauhan ma'am has been iconic in transcending learning beyond boundaries. Hence, we're unhindered in our mission to inculcate a state of happiness in every child to ensure a peace-loving world. The twelfth iteration of Amity Tarang 2021 contained a plethora of engaging events that had truly evoked happiness in every participant, judge and guest who witnessed the mega event.

Amity Tarang 2021 was bigger, bolder, and better than ever before with multilingual, multidimensional, and multi-tasking competitions in fourteen categories with thirty-seven schools across India, 274 participants and twenty-three celebrated judges from as far as the U.S.A. After observing the competitions, the judges had unanimously commented that, with such innovative and talented children, the nation is in good hands.

- Highest Points: Amity International School, Noida, Amity International School, Sector-46, Gurugram and Amity International School Saket
- Trophy Winner: Amity International School, Sector-43, Gurugram

The event concluded with an inspiring speech by the Principal, Ms. Divya Bhatia congratulating the winners and expressing her deepest gratitude to the Chairperson ma'am and Founder President sir for their constant guidance and motivation. The virtual ceremony came to an end with warm Diwali greetings for happiness and good health.

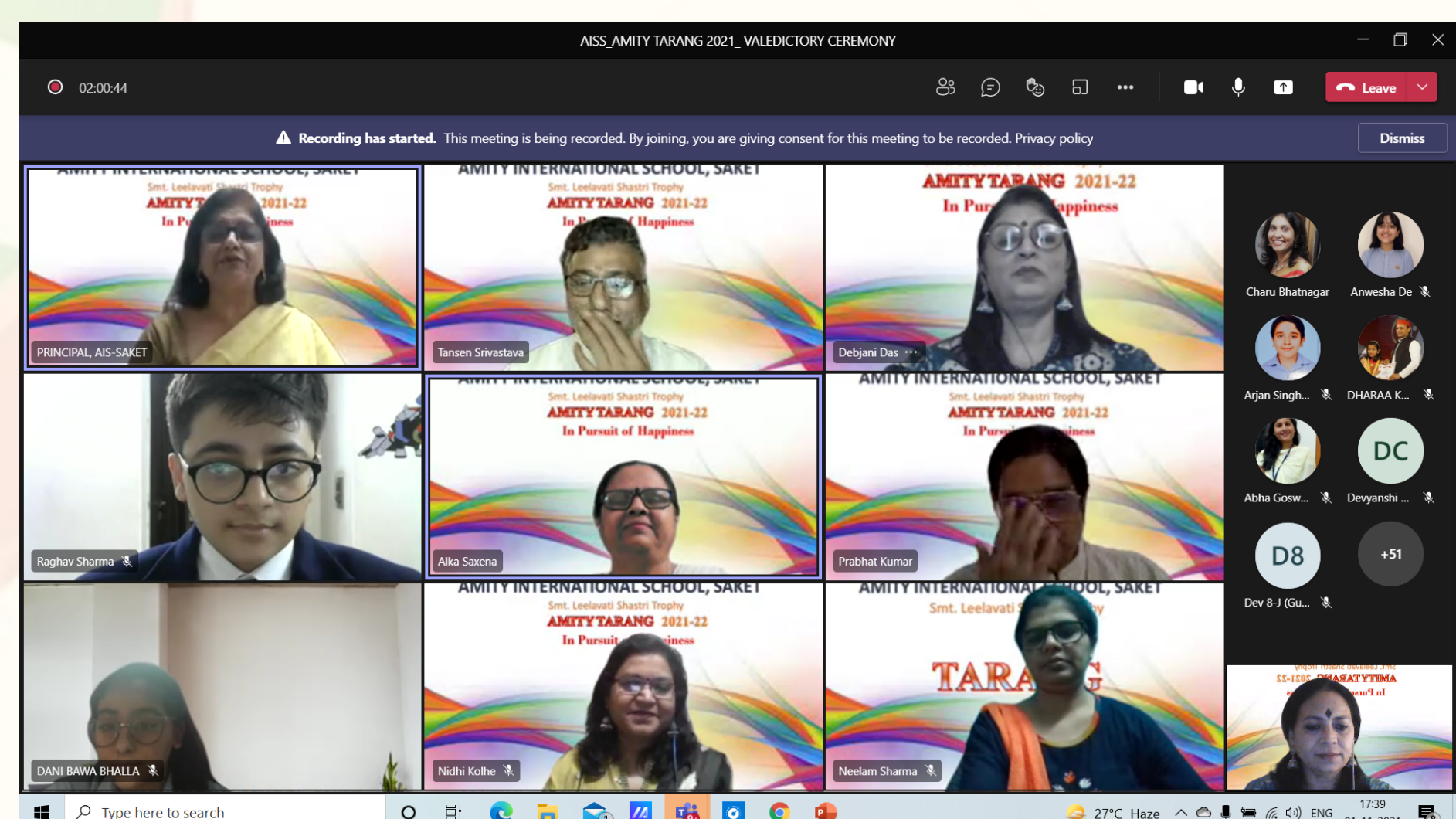
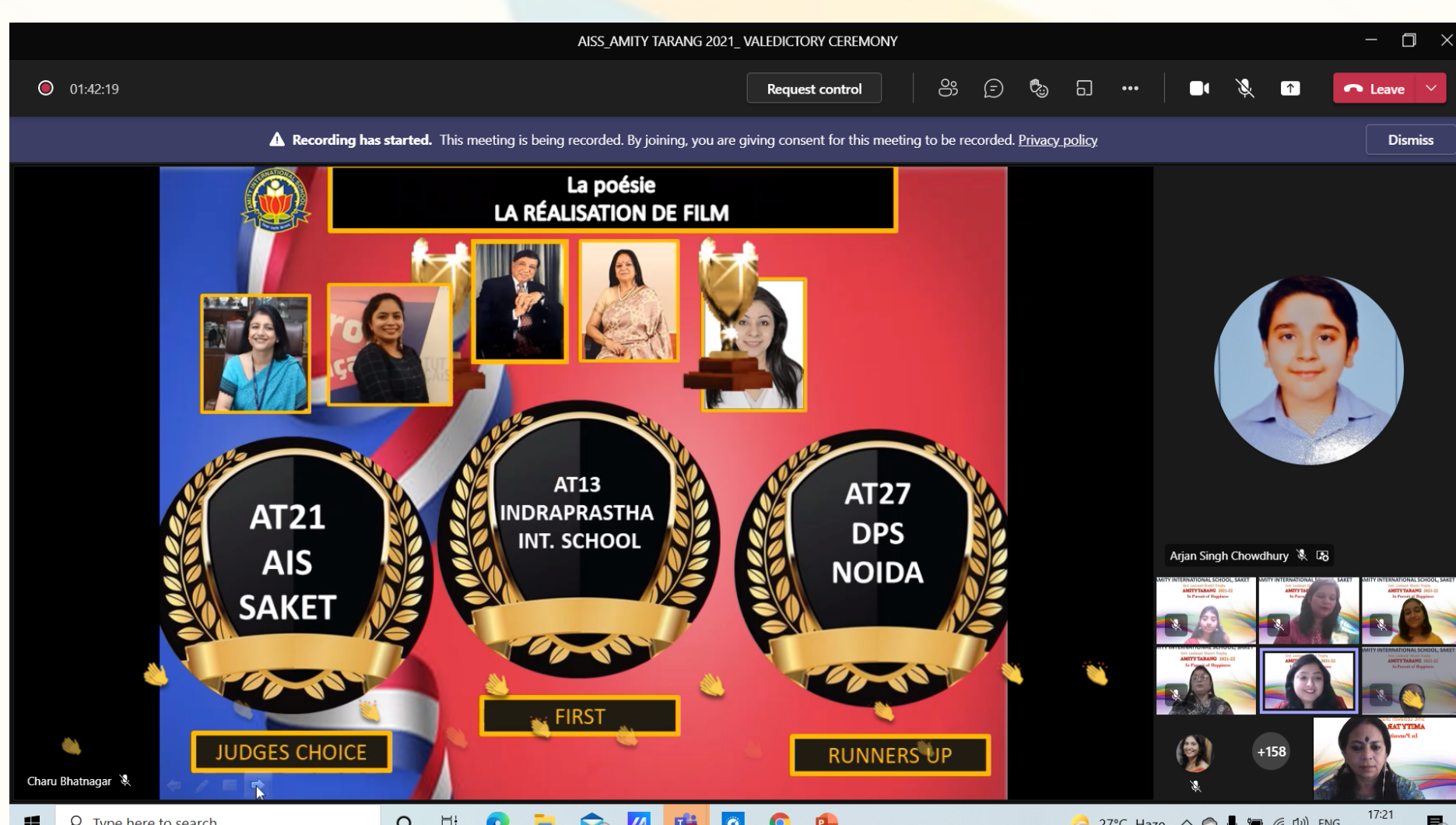

CREATIVES

ART AND WRITING



THE SKETCHBOOKS & THE SUBLIME



Neeman Mangal (XII-A) on life during the pandemic.



Vihaan Arora KG-B with his Dussehra Inspired artwork.



Udbhav Kumar of II-A gave a wonderful expression to his 'Warli' painting



Unnat Vohra KG A meticulously created beautiful crafts, taking inspiration from 'Dussehra.'



Aariana Sarkar of V-A creates a visual tempo with her 'Rhythm' Art.



Pankhudi Rao (X-C)'s Mandala artwork on Saving Elephants



Moulik Bhardwaj of III-C made a lovely Lotus flower composition.



FROM INKSTROKES TO INTROSPECTION

IN A CAGE

The days pass by,
Meshed into one another,
A monochromatic blur,
Devoid of sound,
Of colour,
Of emotion; anger, hatred, love, passion,
There is nothing.
It seems as if I watch my life,
As a powerless spectator,
As if my spirit,
And my body are separate entities,
With my soul being trapped in this foreign cage,
Viewing helplessly, my daily ordeals,
Through my own eyes and,
Feeling the pain, when it comes,
If ever,
Knowing the emptiness,
Brewing up within,
And yet, being apart from
Everything.



**It is curious, this state,
That I find myself in,
Yet it is continual,
As the Earth goes round,
As day turns to night,
And night turns to day,
But at the end of this darkness,
This long, black tunnel,
Is a passageway to another,
Just as long,
Just as black,
Just as devoid,
Of the saving grace of light.
I reach out,
In the blind darkness,
Groping for something,
Some hope, love, light,
Anything to fight this gloom,
Or even something to cling to,
To climb on,
Like a creeping vine,
Entwined in the boughs of an ancient oak,
Its strength my support,
Helping me persevere,
Through the endless storm,
Of obstacles I face.
I find nothing.**

**I bleed out,
Alone, cold, unforgiving,
Of myself,
It seems as if my hands,
Have done this deed,
But, deep within I know it is,
My spirit, my mind,
Desperate to break free,
From my physical confines,
A madness takes over me,
As I cleave to the extreme,
And finally, finally,
My inner being is,
From this fiendish cage,
Eternally freed.**

By Tanya Ganguly (XI-C)

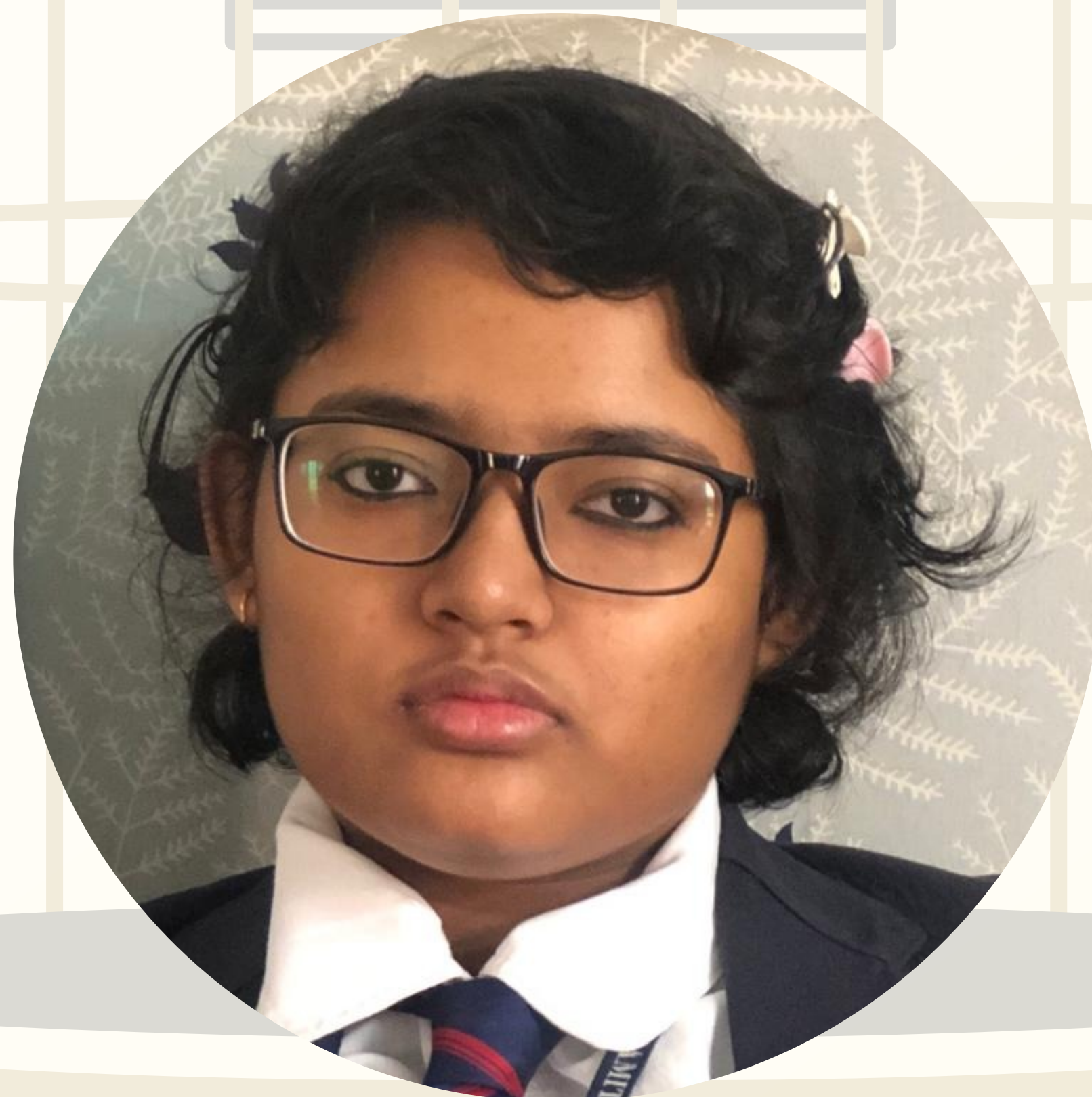

Missing School

School, school, school

It was so cool!

**The problems we faced,
The sadness that raised!**

We are so sad,

We used to be glad!

**Playing and studying all day,
Hope it's not too far away!**

We are in a Cage

Filled with rage!

School, school, school

Oh, it was so cool!!

By Rishita Gulati (IV-B)



Guide to Goodbye

No,

**We ought not say a thing in our last presence
So that the memories of past hold their essence**

No,

**We ought not meet the exquisite eyes
So that they don't shed their pity cries**

No,

**We ought not hold hands
So that they don't hold us back with their commands**

No,

**We ought not even smile at each other
So that they don't speak excuses any further**

No,

**We ought not make promises to meet again
So that our heart is not filled with hope of, when?**

And no,

**We ought not to let the words play its part
So that they don't hinder our plans of restart**

But yes,

**With doing all this, to at least try
I believe we would be ready to say goodbye**

By Saamya Arora (X-B)



Calm Before the Storm

**When the darkest clouds are lifted
And the hindering doubts pass
The sanguine surge of ardor is
The calm before the storm**

**When dawn is on the horizon
And the radiant hues are cast
The birth of dazzling dreams is
The calm before the storm**

**When the sun is up and shining
And our morals at their peak
The ripple of perseverance is
The calm before the storm**

**When the sun goes down and comes again
And new inspirations sink in
The crumbling sense of self doubt is
The calm before the storm**

**The revolution of life
And the hope of a worthy world
The endeavors of the men in the streets are
The calm before the storm**

By Samaira Sachdeva (X-C)



ACHIEVEMENTS



S.NO	DATE	NAME OF ORGANISER/SCHOOL	NAME OF PARTICIPANT/s	CLASS/SEC	ACHIEVEMENT
1	10-11-2021	Dr. AK SAHA CONTEST SPRING DALES - Science Quiz And Investigatory Project	Harsaaj singh Wnader, Aditya Agrawal, Kashvi Goel, Anwasha Satpathy	XII, XI	Winners of overall trophy
2	15/10/21	APJ Abdul Kalam Ignited Mind Children Creativity and Innovation Award 2021- Science Project- Weed detection Mechanism using Data Pre processing	HIMANSHU SHARMA	XI	SELECTED IN THE TOP 20 STUDENTS AND AWARDED AN APPRECIATION
3	21/10/21	Delhi State Roller Skating Championship-Speed-500mt RACE	Viraj Bhakuni	Vth D	Bronze Medal (Third Position)
4	23/10/21	Delhi State Roller Skating Championship-Speed-200mt RACE	Viraj Bhakuni	Vth D	Bronze Medal (Third Position)
5	15/10/21	Indian Schools Debating Society (Second Round Qualified)- National Camp	Nitya Jain	VIII	Among the top 50 speakers
6	10-06-2021	eAIMUN 2021 (AERC and AMITY Schools) Model UN conference	Satvik Tola, Himanshu Sharma, Dev garg, Chaitanya Bahl, Mehar Kapoor, Samaira Sachdeva	VIII-X	Best delegation for rep Israel and individual awards
7	24/10/21	Delhi State Legal Services Authority Model UN debate (Role of Youth in enforcing Rights of Children in India)	Chaitanya Bahl	IX	Best speaker award
8	25.10.21	AIIMS ON WORLD STROKE DAY-ESSAY -HOW WILL I MAKE MY COUNTRY STROKE FREE	NITYA JAIN	VIII	THIRD PRIZE
9	25.10.21	ALL INDIA DHAMMIKA KAI KARATE FEDERATION- 12TH DHAMMIKA KAI CUP KARATE CHAMPIONSHIP 2021	SAMAKSHH GUPTA	V-D	Bronze Medal (Third Position)
			YATHARTH MADAN	VI	Bronze Medal (Third Position)
			ANANYA SAGAL	VI	
10	9.11.2021	Break Out'21 - AIS Saket	Pranav Gupta (Electric Guitar)	XII	Third Prize
			Prashast Kolhe (Bass Guitar)	XII	First Prize
			Aditya Aeri (Drums)	XII	First Prize
			Sreyas Hariharan (Unique Instrument - Violin)	XII	Second Prize
			Pranav Gupta,Kaveri Arun,Aditya Bhalla,Deetya Tripathi,Prashast Kolhe, Aditya Aeri, Sreyas Hariharan,Parth Khullar & Rishika Gupta (Overall)	X - XII	
11	23/10/21	Delhi State Roller Skating Championship G.R International School Bawana	Anusha Sawarkar	I-C	3rd Bronze Medal
12	01-11-2021	Amity , Saket Hindi katha vaachan pratiyogita (Jr)	Vanshika Sharma	VI	Judges choice
13	01-11-2021	Amity , Saket Hindi katha vaachan pratiyogita (Sr)	Raghav Sharma	IX	First Prize
14	01-11-2021	Amity , Saket sanskrit kavya Tarangini (Geeta shlok vaachan)	R.Agamyia	IX	First Prize

ACKNOWLEDGEMENTS

Student Editors

Ravina Rastogi (X-A)

Saamya Arora (X-B)

Raabia Ali Abidi (VIII-B)

Editorial Correspondents

Aarushi Gupta (XII-G)

Prisha Dubey (X-A)

Manya Bhatia (XI-E)

Editorial Designers

Raghav Agrawal (XII-C)

Divyaansh Seth (XI-A)

Editor(s)-in-Chief

Nandita Bansal (XII-E)

Sarthak Sahoo (XII-G)